

CLASSIC 310 FT

(Folding Transom)

SPECIFICATIONS

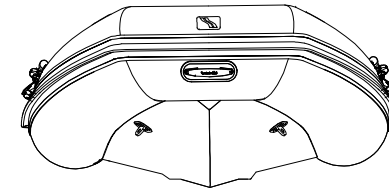
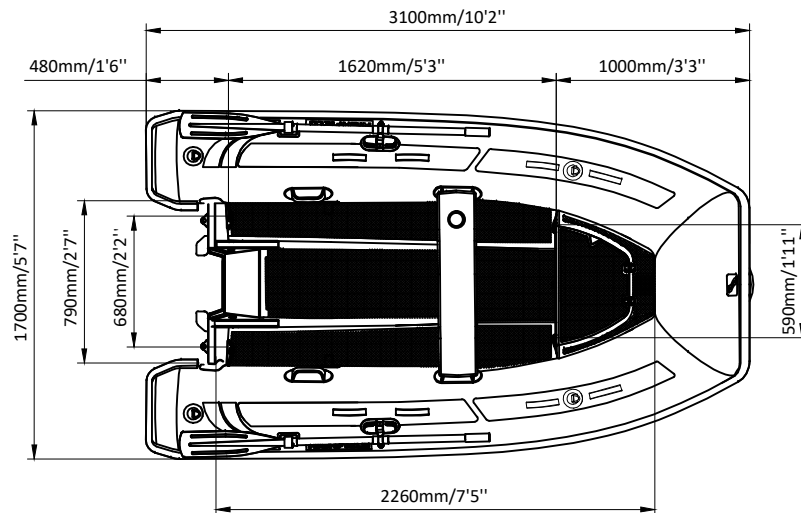
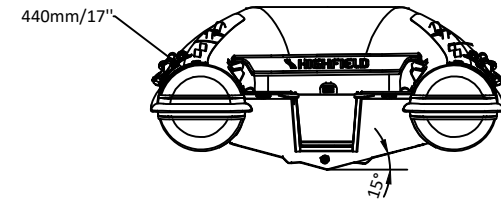
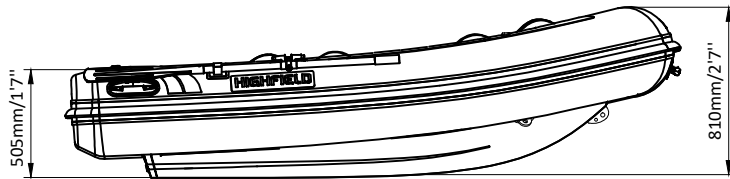

SPECIFICATIONS AND MAXIMUM CAPACITIES (Subject to change without notice. Tolerances: dimensions $\pm 2.5\%$, weights $\pm 5\%$) Note: red means lifting eyes.

MODEL	ISO 6185 PART	ISO 6185					Outboard Engine				Molded seat		Oars		/		Fuel tank Capacity		Wet Weight (Approximate) 20HP (14.92KW)		AIR CHAMBERS						
			KG	LB	#	KG	LB	Shaft	Max power		Max weight		KG	LB	KG	LB	/	/	L	GAL		KG	LB	PSI	BAR		
									KW	HP	KG	LB															
CL310FT	2	C	550	1213	5	375	827	S	14.92	20	104.5	230	62	137	3	6.6	1.5	3.3	/	/	/	/	171	377	3	3.63	0.25

Weight: boat only.

CLASSIC 310

(Short Shaft)

SPECIFICATIONS

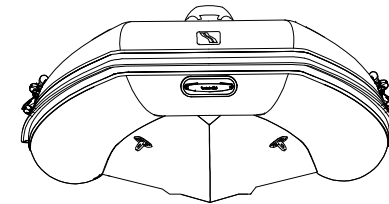
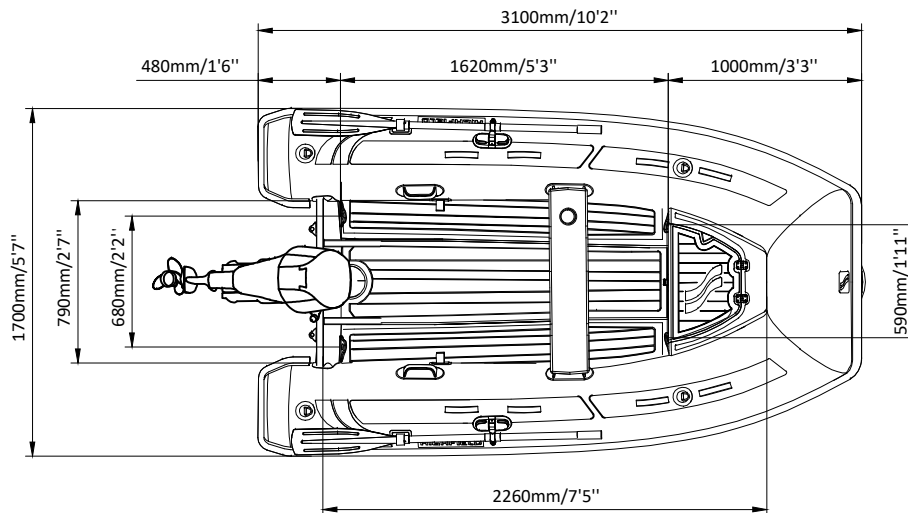
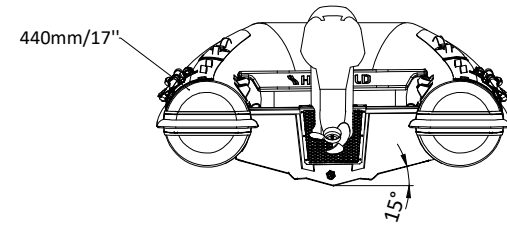
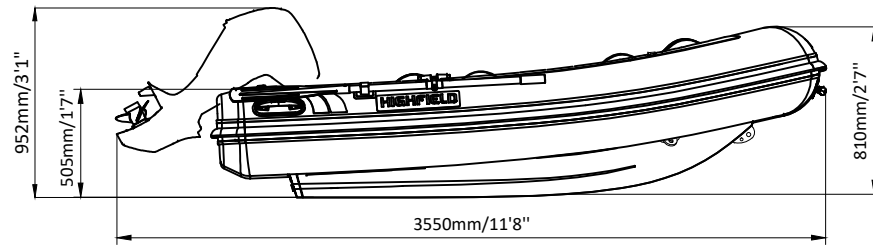

SPECIFICATIONS AND MAXIMUM CAPACITIES (Subject to change without notice. Tolerances: dimensions $\pm 2.5\%$, weights $\pm 5\%$) Note: red means lifting eyes.

MODEL	ISO 6185 PART	ISO 6185	Crew		#	Weight		Shaft	Outboard Engine				Molded seat		Oars		/		Fuel tank Capacity		Wet Weight (Approximate) 20HP (14.92KW)		AIR CHAMBERS	Pressure			
			KG	LB		KG	LB		Max power	Max weight	KG	LB	KG	LB	KG	LB	L	GAL	KG	LB	PSI	BAR					
									KW	HP	KG	LB															
CL310	2	C	550	1213	5	375	827	S	14.92	20	104.5	230	62	137	3	6.6	1.5	3.3	/	/	/	/	171	377	3	3.63	0.25

Weight: boat only.

CLASSIC 310 FT

(Folding Transom)

SPECIFICATIONS

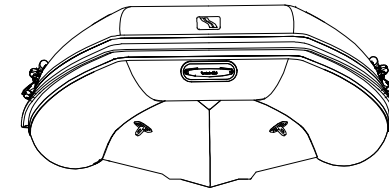
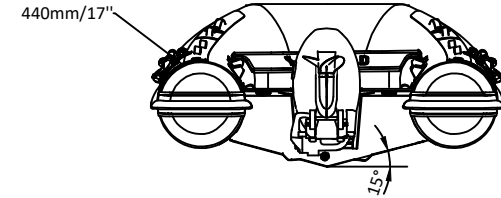
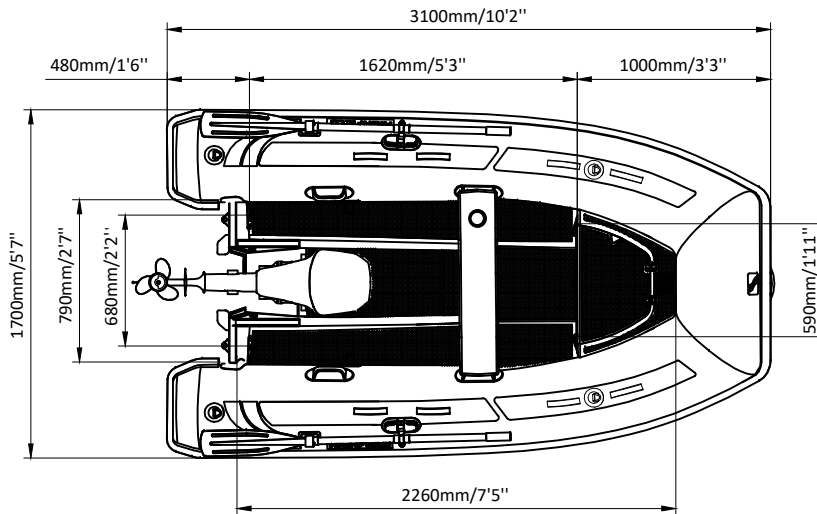
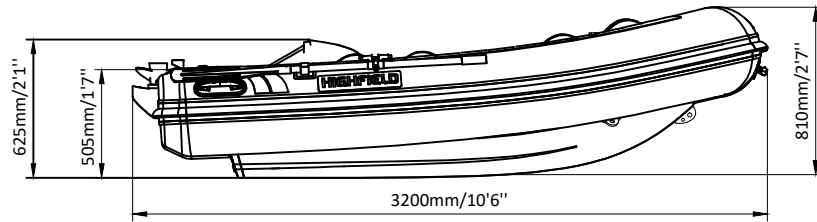

SPECIFICATIONS AND MAXIMUM CAPACITIES (Subject to change without notice. Tolerances: dimensions $\pm 2.5\%$, weights $\pm 5\%$) Note: red means lifting eyes.

MODEL	ISO 6185 PART	ISO 6185					Outboard Engine				Molded seat		Oars		/		Fuel tank Capacity		Wet Weight (Approximate) 20HP (14.92KW)		AIR CHAMBERS						
			KG	LB	#	KG	LB	Shaft	Max power		Max weight		KG	LB	KG	LB	/	/	L	GAL		KG	LB	PSI	BAR		
									KW	HP	KG	LB															
CL310FT	2	C	550	1213	5	375	827	S	14.92	20	104.5	230	62	137	3	6.6	1.5	3.3	/	/	/	/	171	377	3	3.63	0.25

Weight: boat only.

CLASSIC 310

(Short Shaft)

SPECIFICATIONS

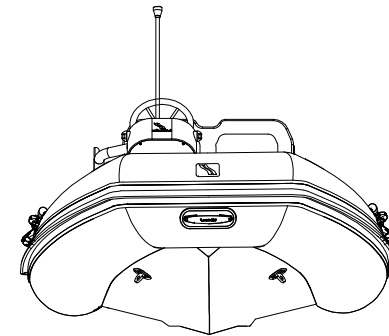
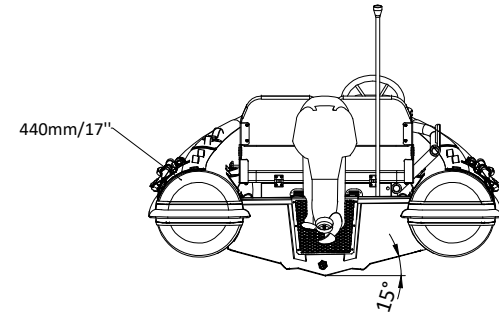
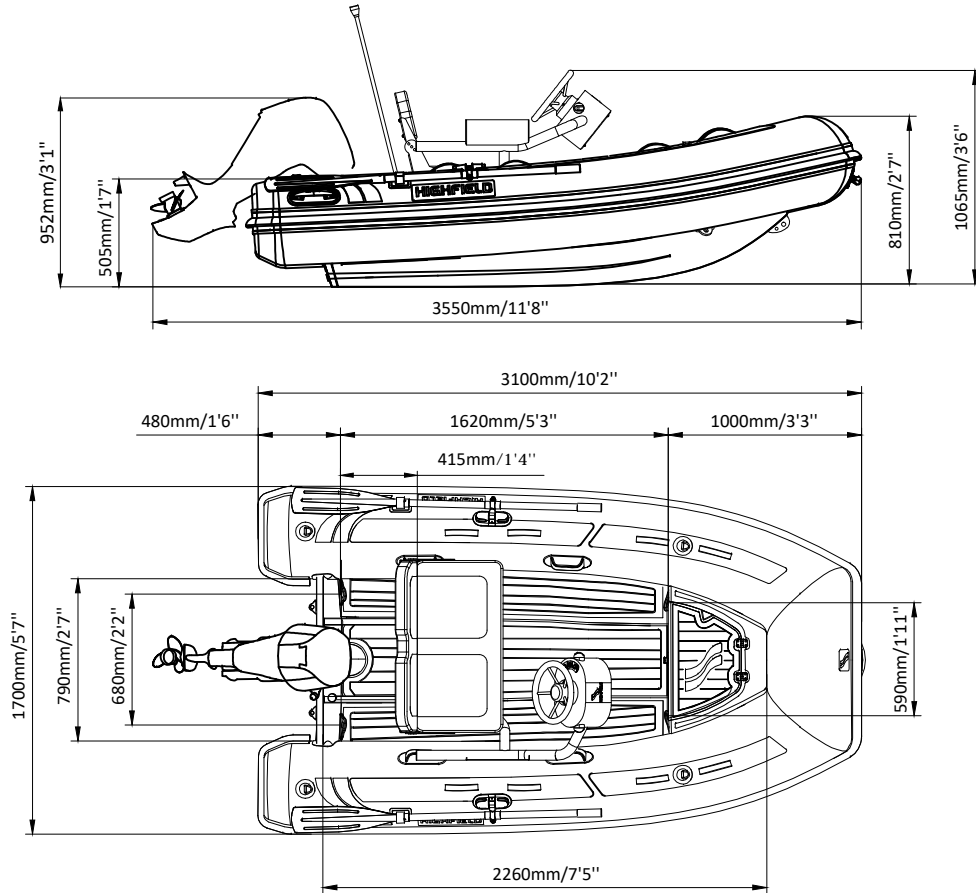

SPECIFICATIONS AND MAXIMUM CAPACITIES (Subject to change without notice. Tolerances: dimensions $\pm 2.5\%$, weights $\pm 5\%$) Note: red means lifting eyes.

MODEL	ISO 6185 PART	ISO 6185	Person		#	Person		Shaft	Outboard Engine				FCT		Molded seat		Oars		Fuel tank Capacity		Wet Weight (Approximate) 20HP (14.92KW)		AIR CHAMBERS	Pressure			
			KG	LB		KG	LB		Max power	Max weight	KG	LB	KG	LB	KG	LB	L	GAL	KG	LB	PSI	BAR					
									KW	HP	KG	LB															
CL310	2	C	550	1213	5	375	827	S	14.92	20	104.5	230	62	137	36	79	3	6.6	1.5	3.3	/	/	207	456	3	3.63	0.25

Weight: boat only.